

ENWORK

ZORI T-LEG FLIP TABLE
INSTALLATION INSTRUCTIONS

TRAINING TABLE



Z I 0 0 0 3

Flip Table with Spacer and Washer- Rev B

INSTALLATION GUIDE

3) ASSEMBLY OVERVIEW :

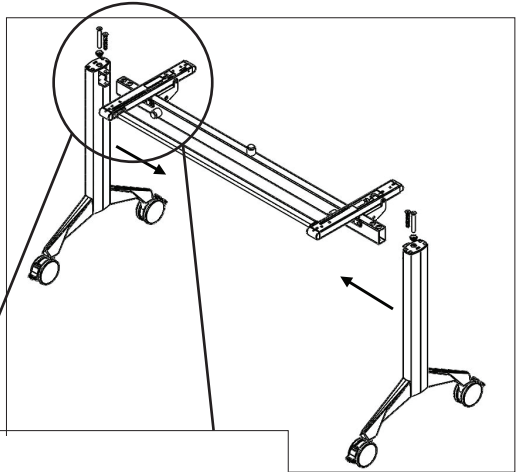

- 3.1.1) Locate the pre-assembled legs and pre-assembled flip frame sub-assembly
- 3.1.2) Locate the M8 x 70mm bolts, M8 x 55mm bolts, spacers and washers
- 3.1.3) Slide the legs onto the flip frame so that the top tab inserts inside the tube and the bottom tab is outside of the bottom face of the tube.

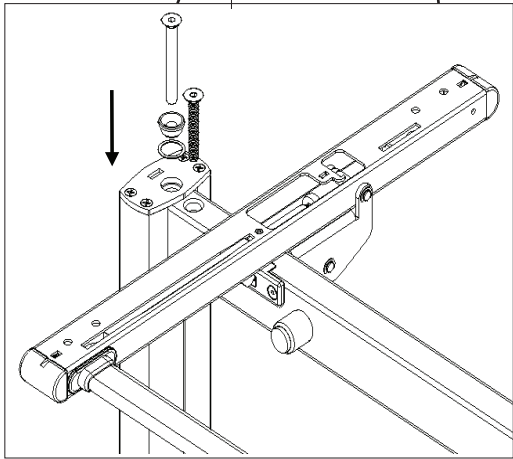
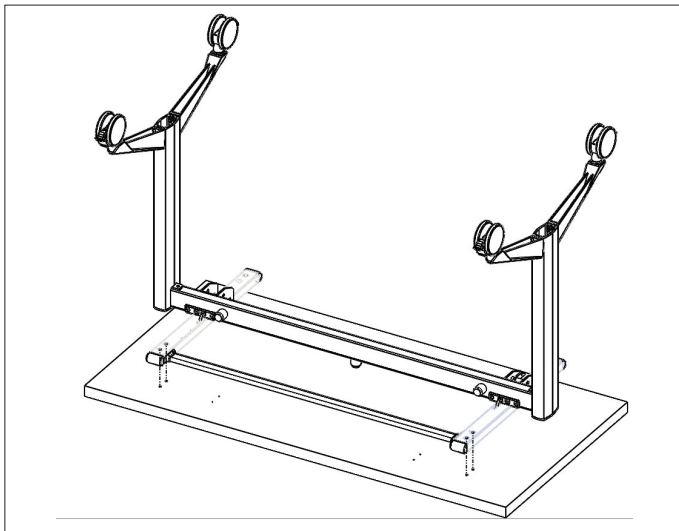

FIGURE 3.1

- 3.2.1) After tube of flip frame is inserted, use (1) M8 x 70mm bolt, (1) Spacer and (1) Washer to secure frame to leg in outer hole as shown.
- 3.2.2) Use M8 x 55mm bolt to secure frame to leg in inner hole as shown.
- 3.2.3) Ensure that bolts are fully tightened.
- 3.2.4) Repeat previous steps for other leg.

FIGURE 3.2



- 3.3.1) Lay the top face down on a non-marring surface.
- 3.3.2) Place the frame on the top with the black flip mechanisms spaced evenly from the sides of the table.
- 3.3.3) Line up the holes in the flip mechanisms with the pre-drilled holes in the work surface.
- 3.3.4) Attach the frame to the top with the included wood screws.
- 3.3.5) Insert the included Cap Covers into the holes in the flip mechanisms to cover the screws.

FIGURE 3.3

ENWORK

1.800.815.7251

www.enwork.com

12900 Christopher Dr. Lowell, MI 49331

Specifications subject to change without notice.

Rev 02.2020