

Landing

Laminate Team Table



Installation Instructions

1) Parts and Fasteners Included

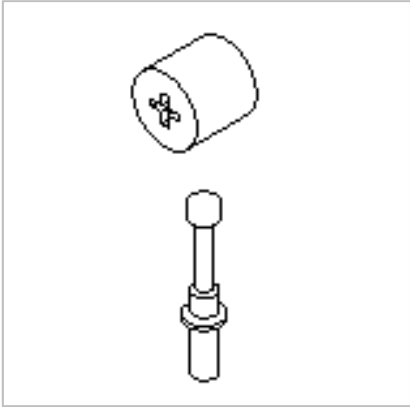

24mm Cam Dowel

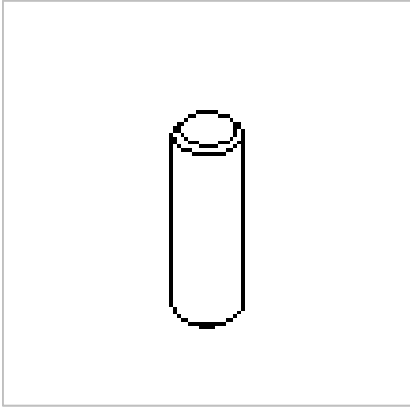

8mm x 1in Dowel Pins

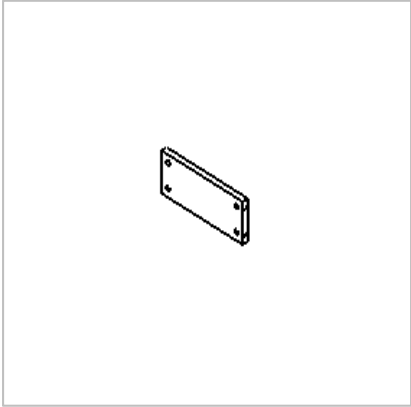

Keel Block

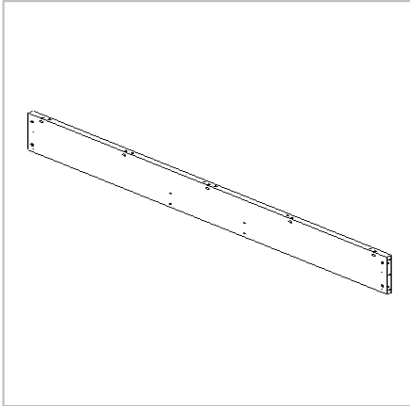

Keel

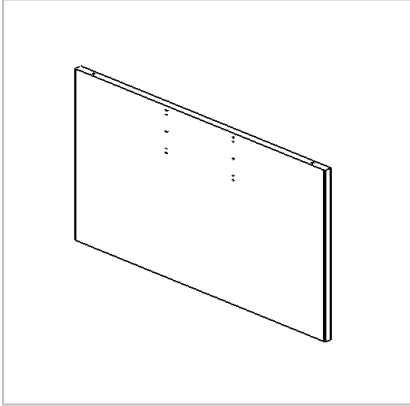

End Panel

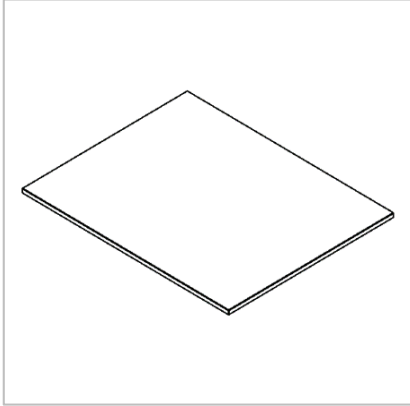

Top Surface

1) Parts and Fasteners Included

Optional Foot Bar Parts

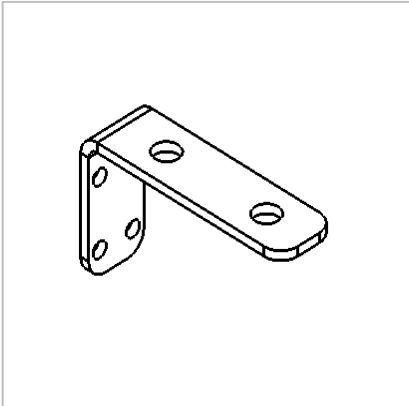

Angle Bracket

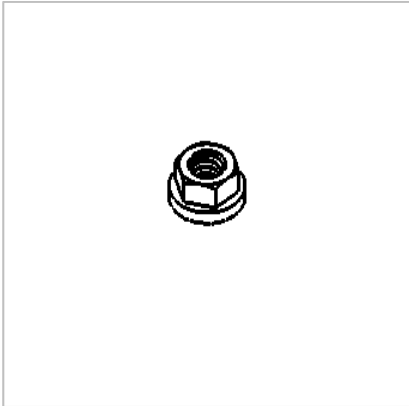

5/16 Flange Nut

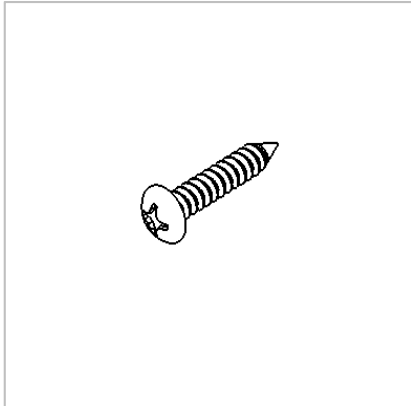

#10 x 1 Phillips Screw

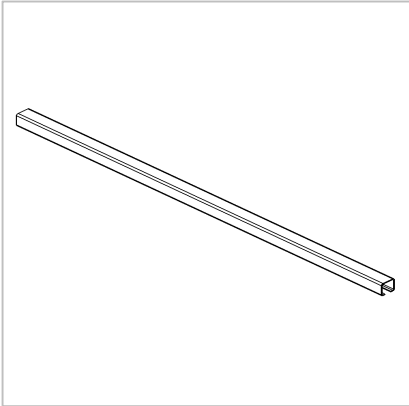

Foot Bar Weldment

2) Tools and Supplies Required

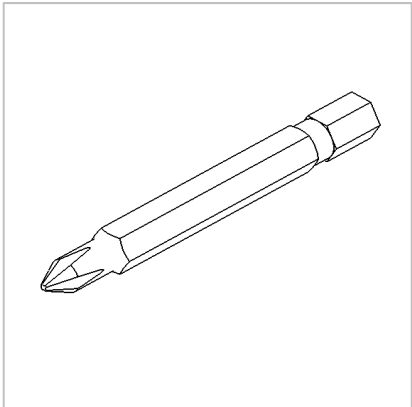

Phillips Drive

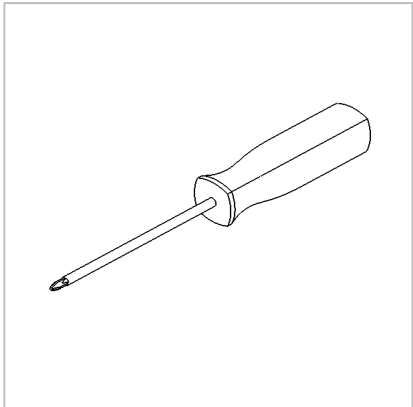

Phillips Head Screw Driver

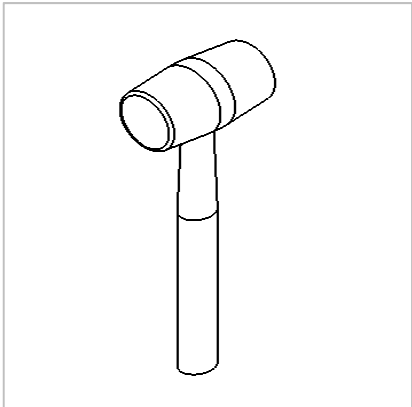

Rubber Mallet



Cordless Drill

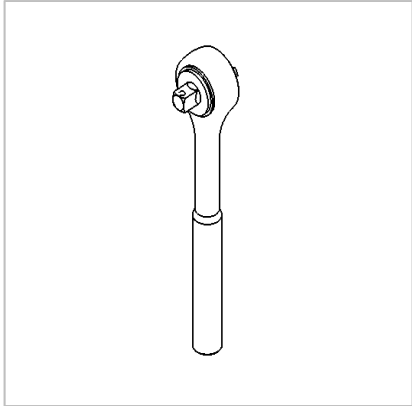

Ratchet

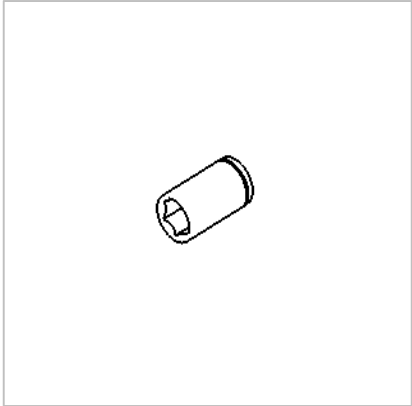

5/16 Deep Socket

4) Assembly: Keel Sub Assembly

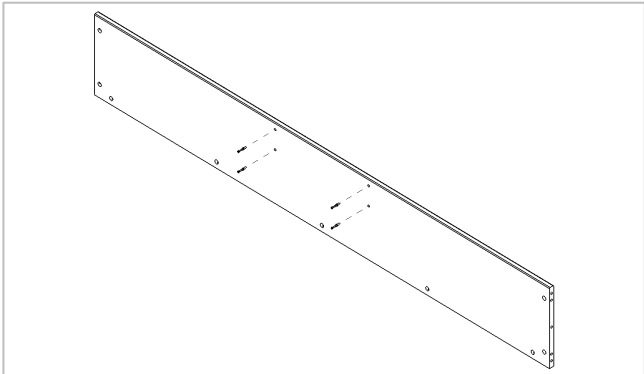

Fig. 1 Install (4) Cam Dowels Pins into the (4) 5mm pre drilled holes on the Keel. Repeat for second Keel.

Fig. 1

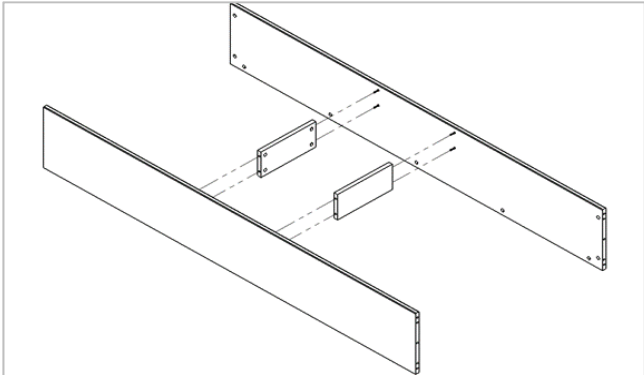

Fig. 2 Assemble Keel Block and Keels. Keel Blocks should be assembled with the Cam Dowel surfaces facing each other (as shown).

Fig. 2

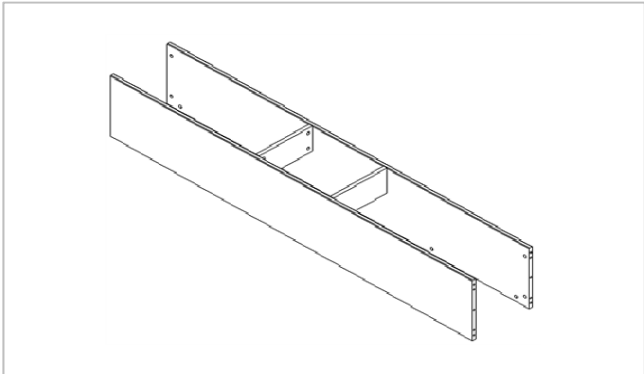

Fig.3 Assemble should be placed as shown (Edge band side up)

Fig. 3

4) Assembly: Base Sub Assembly

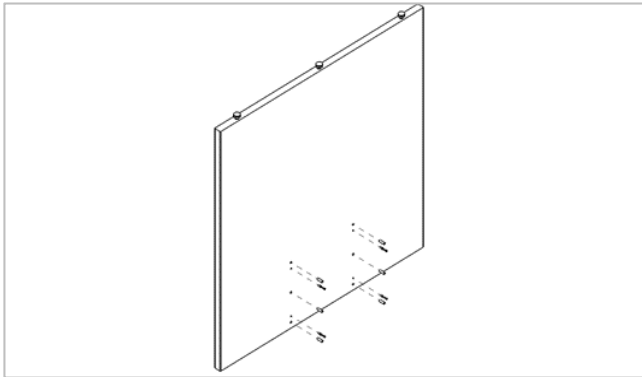

Fig. 4

Fig. 4 Install (4) Cam Dowels Pins & (6) 8mm Dowels Pins into (10) centrally located pre drilled holes on the End Panel. Repeat for second End Panel.

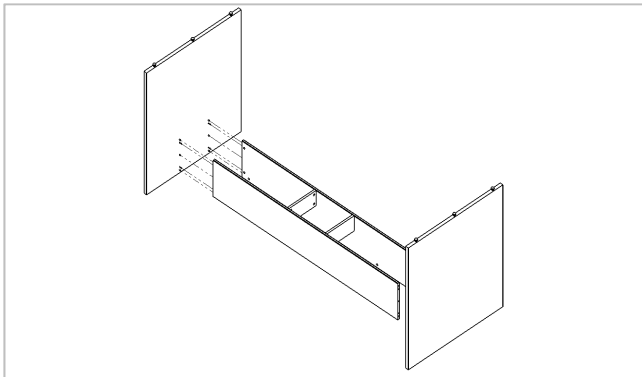

Fig. 5

Fig. 5 Align the Cams Dowels and Dowel Pins and assemble the (2) End Panels and the Keel Sub Assembly.

Assemble with End Panel Glides up (as shown).

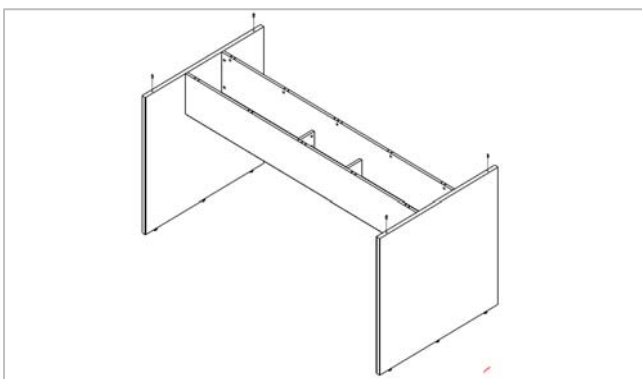

Fig. 6

Fig. 6 Ensure all Cam Dowels are tight and flip the entire Base Sub Assembly into an upright position (End Panel Glides down). Be careful not to damage End Panel edges and corners. Install (4) 8mm Dowel Pins into the (2) End Panels.

4) Assembly: Top Assembly

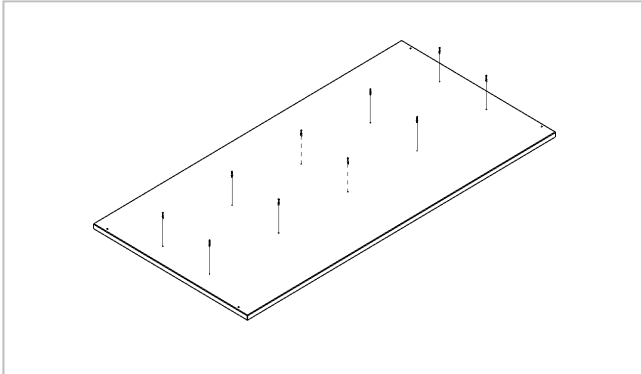

Fig. 7

Fig. 7 Insert 8mm Cam Dowel Pins into the 5mm pre-drilled holes on the underside of the Top Surface (bottom surface shown).

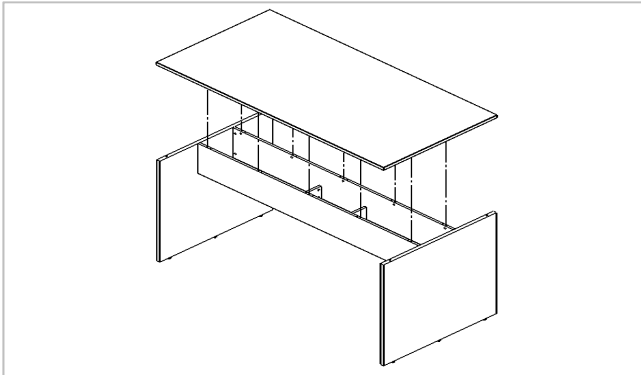

Fig. 8

Fig. 8 Align the (4) 8mm Cam Dowel Pins and Cams and assemble the Top Surface and the Base Sub Assembly. Cam the Top Surface and the Base Sub Assembly together.

Level the Landing Table using the End Panel Levelers.

4) Assembly: Optional Foot Bar Assembly

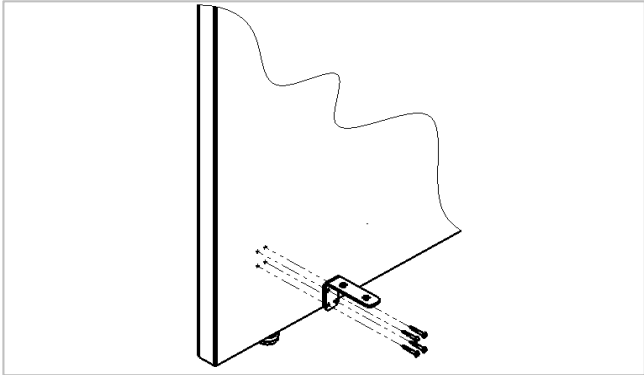

Fig. 9

Fig. 9 Attach Angle Bracket to End Panel using (4) #10-1 Phillips Screw. Use predrilled holes. Repeat for opposite End Panel.

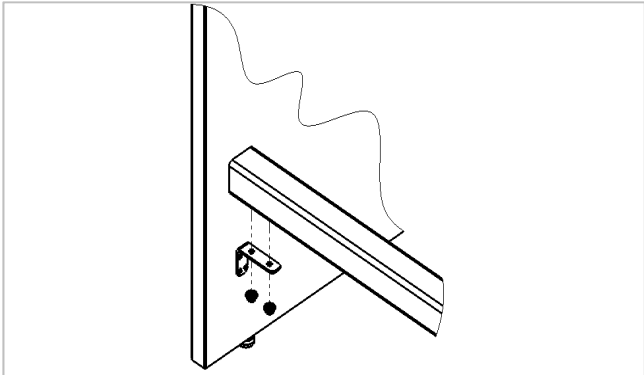

Fig. 10

Fig. 10 Attach foot Bar Weldment using (2) 5/16 Flange Nuts. Repeat for Opposite End Panel

ENWORK

12900 Christopher Drive Lowell, MI 49331
800.815.7251 www.enwork.com

Specifications subject to change without notice.